



Model 8400 Pallet Truck

The new definition of dependability.

The Model 8400 is the toughest pallet truck you can buy.

It features solid steel components. Extra steel gusseting to protect vital parts. Heavy-duty reinforcement for the battery box. And a large, tough motor for robust performance.

You'll also get exceptional productivity with our exclusive **ACR System™**. Raymond's advanced AC technology provides faster acceleration, better control, and greater energy efficiency than DC systems, with less downtime and maintenance.

The innovative Model 8400 pallet truck is designed for easy operation and driver comfort. And you can have all this dependability and performance at a lower cost of ownership than other brands' trucks.

Get these advantages with the Model 8400:

- Heavy-duty design
- Rugged steel components
- Exclusive **ACR System** technology
- Faster acceleration and travel speeds
- More uptime
- Lower ownership costs



RAYMOND
Above. And beyond.®

www.raymondcorp.com

The Raymond® Model 8400 Pallet Truck

Tougher. Faster. Easier. Smarter.

Rugged dependability.

- Special gusseting protects components
- Solid steel pull rods, pins, bushings, castings
- 50% thicker steel forks and skid bars
- Heavy-duty reinforced battery box
- Large drive motor

Exclusive ACR System

- Advanced AC technology
- More energy efficient than DC
- Faster, smoother operation
- More work per battery charge
- More uptime, more productivity

More comfort and productivity.

- Roomy platform with lean points
- Ergonomically designed, intuitive controls
- Faster travel and pick speeds
- Up to 10 settings to match operator and application
- Patented *CoastPRO*™ System speeds picking

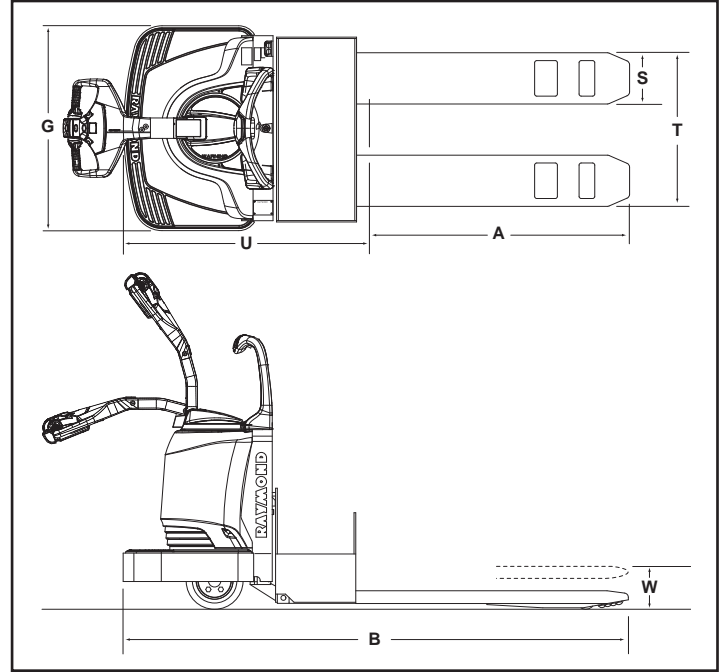

Lower ownership costs.

- Fewer parts, less maintenance with AC
- Less downtime for battery charging, changing
- Fast, easy access for maintenance
- Error code display for quick troubleshooting
- More productivity, better bottom line

MODEL 8400 DIMENSIONS AND SPECIFICATIONS													
		Single Pallet (6K)					Double Pallet (6K & 8K)				Triple Pallet (8K)		
A	Actual Fork Length	in.	32	36	42	48	60	84	93	96	103	115	144
B	Overall Length	in.	74.8	78.8	84.8	90.8	102.8	127.3	136.3	139.3	146.3	158.3	187.3
F	Weight, Less Battery*	lb.	1175	1190	1212	1234	1284	1570	1610	1620	1650	1770	1870
G	Truck OAW	in.	36										
S	Fork Width (each)	in.	9.0					10.0					
T	Fork OAW	in.	27.0					27.5					
U	Head Length	in.	42.8					43.3					
W	Elevated Height	in.	9.25										
	Max. Capacity	lb.	6000					8000					
	Drive Tire, rubber	in.	12 x 4.75					12 x 4.75					
	Load Tire, poly (2)	in.	3.25 x 5.91					3.25 x 5.91					
	Travel Speed	mph	9.0 Unloaded		6.5 Loaded			9.0 Unloaded		6.2 Loaded			

* Deduct 210 lbs. for 6K weights for Double Pallet Jacks

RAYMOND
Above. And beyond.®

The Raymond Corporation
P.O. Box 130
Greene, New York 13778-0130
Toll free 1 (800) 235-7200
Fax 1 (607) 656-9005

www.raymondcorp.com

Due to continuous product improvements, specifications are subject to change without notice or obligation. Above. And beyond., Raymond, CoastPRO and ACR System are U.S. trademarks of The Raymond Corporation.

©2007 The Raymond Corporation, Greene, NY. Printed in USA. SIFB-0115 905CT-40